

### T106A DUAL CONTROL SHOWER PANEL

#### **HORNE SHOWER PANEL WITH DUAL CONTROL SHOWER VALVE and SWIVEL SHOWER HEAD**

Includes integral TMV3 thermostatic shower valve pre-plumbed within a white (RAL 9010) powder coated aluminium panel with hand controls and easy clean swivel shower head in chromium plated finish.

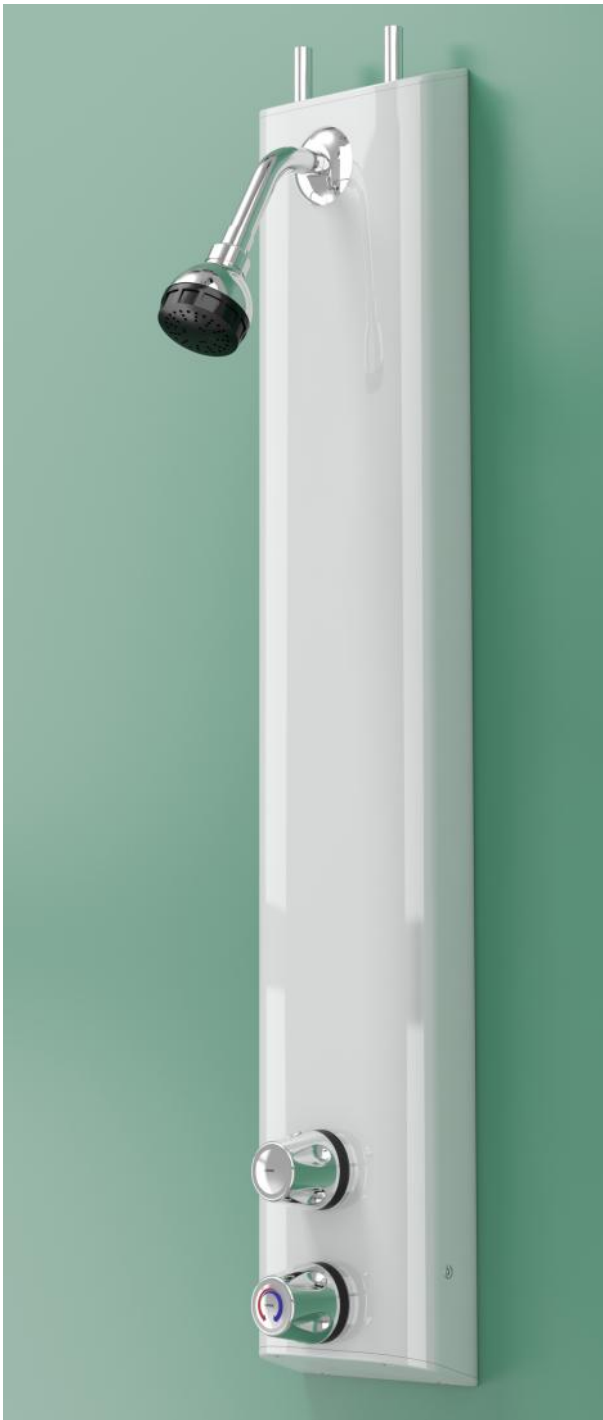

#### **FEATURES & BENEFITS**

- Robust powder coated (RAL 9010) panel and fittings ensure long lifespan
- Integral TMV3 Scheme Approved shower valve - dual control
- Easy clean swivel shower head
- Fully pressure and performance tested pre-plumbed assembly
- 8 L/min flow regulator for water and energy conservation
- Highly suitable for retrofit applications
- Fast and easy installation
- Low level integral isolating service valves for ease of maintenance
- Optional accessory:
  - Pipe cover in same profile as panel

The TSV1-3 thermostatic shower valve is WRAS & TMV3 Scheme Approved.



Certificate No. FM 1224

Dimensions in mm

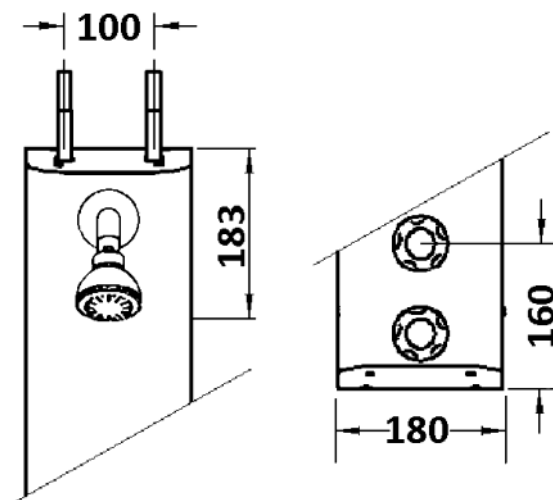
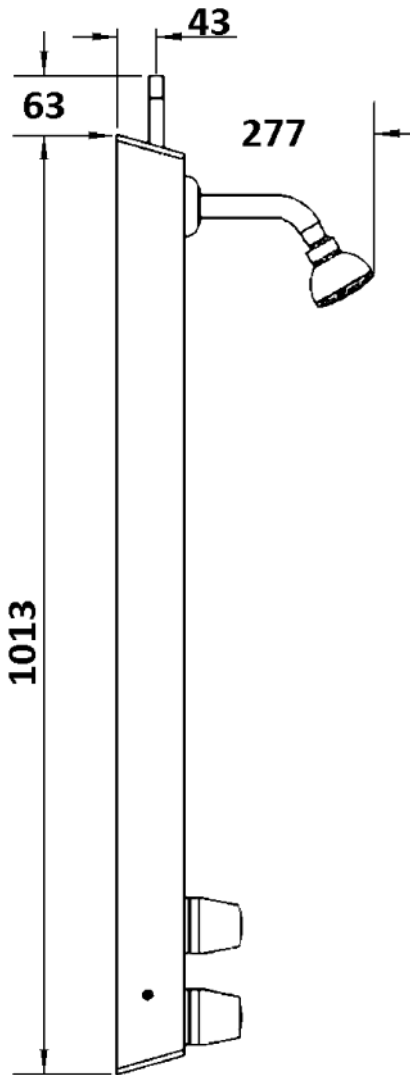

The T106A shower panel is pre-plumbed with an integral Type 3 and WRAS approved thermostatic mixing valve, which features:



- Integral fine mesh strainers provide essential protection to the internal mechanism of the valve & ancillary fittings
- Angle pattern inlets enable easy access to the strainers
- Integral check valves prevent cross migration of water supplies
- Flushing facility to allow water supplies to be flushed clean during commissioning

### Operating Conditions:

- Mixed water temperature preset to 41°C
- Range of hot water supply temperature: 52 — 85°C
- Maximum static pressure: 10 bar
- Minimum differential between hot water temp. and mixed water temp.: 5°C
- Range of maintained water supply pressures: 0.2 — 5 bar

Hot and cold water pressures do not need to be equal. The lower of the two pressures, however, should not be less than 0.2 bar maintained at the shower head.