

T107A DUAL CONTROL SHOWER PANEL

Includes integral TMV3 Scheme Approved thermostatic shower valve, pre-plumbed within a white epoxy-polyester powder-coated aluminium panel with hand controls, riser rail, flexible hose and three function handset.



FEATURES & BENEFITS

- Robust, anodised and powder-coated (RAL 9010) panel & fittings ensure long lifespan
- Integral TMV3 Scheme Approved dual control shower valve
- Robust riser rail with inclusive design handset holder
- Three function handset with easy-clean and anti-kink 1.25m hose (PVC liner)
- Integral 8 L/min flow regulator for water and energy conservation
- Low level integral servicing valves for ease of maintenance and performance testing
- Fast and easy installation, for new or retrofit applications
- Pressure tested assembly, to 16 bar
- Optional accessories:
 - Pipe cover kit in same profile as panel
 - 2 metre hose, P/N SA-108B

Dimensions in mm Original Drawing Ref: 10330

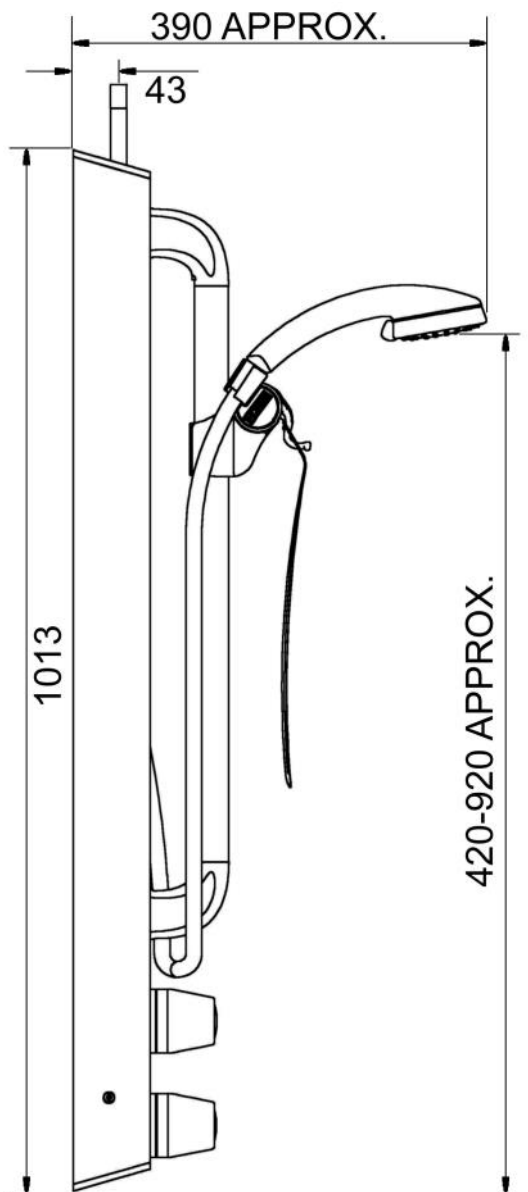

The **T107A** shower panel is pre-plumbed with an integral dual control Type 3 approved thermostatic mixing valve, which features:

- Low level isolating servicing valves
- Integral fine mesh strainers provide essential protection to internal mechanism of the valve and ancillary fittings
- Angle pattern inlets enable easy access to the strainers
- Integral check valves prevent cross migration of water supplies
- Flushing facility to allow water supplies to be flushed clean during commissioning

Operating Conditions:

- Range of temperature adjustment up to a pre-set maximum, usually 41°C at the shower head
- Range of hot water supply temperature: 52 — 85°C
- Maximum static pressure: 10 bar
- Minimum differential between hot water temp. and mixed water temp.: 5°C
- Range of maintained water supply pressures: 0.2-5 bar

Unequal pressures are usually acceptable if gravity-pressure supplies one of the inlets: minimum 0.2 Bar. When both supplies are pumped, pressures should be nominally balanced.

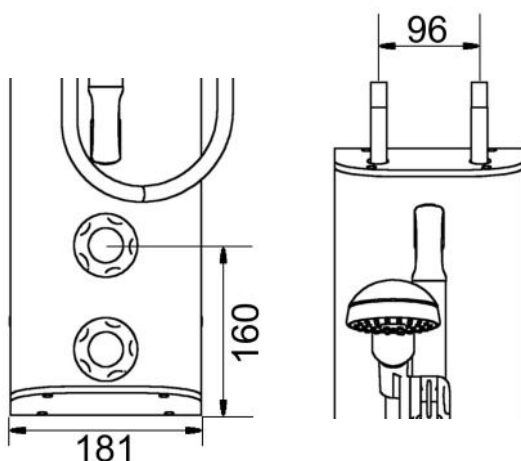

HORNE ENGINEERING LTD, P O BOX 7, Rankine Street, Johnstone, PA5 8BD.

Tel: +44 (0)1505 321455 Fax: +44 (0)1505 336287 email: sales@horne.co.uk web: www.horne.co.uk

