

### T105A2L DUAL CONTROL SHOWER PANEL

HORNE TSV1 SHOWER PANEL WITH DUAL CONTROL THERMOSTATIC MIXING VALVE AND VANDAL RESISTANT SHOWER HEAD

Includes integral Type 3 thermostatic shower valve pre-plumbed within a white (RAL 9010) powder coated aluminium panel with BS 8300 compliant lever controls and vandal resistant shower head in chromium plated finish.



#### FEATURES & BENEFITS

- Robust, powder coated (RAL 9010) panel and fittings ensure long lifespan
- Integral TMV3 Scheme Approved thermostatic valve - dual control
- Pressure & tested pre-plumbed assembly
- Shaped, moulded flow and temperature control levers for less able users
- Fixed vandal resistant shower head
  - \* Large size spray plate
  - \* Two directional spray settings
  - \* Easy to clean and maintain
- Integral 8 L/min flow regulator for water and energy conservation
- Highly suitable for retrofit applications
- Fast and easy installation
- Low level integral isolating service valves for ease of maintenance
- Optional accessories:
  - Pipe cover in same profile as panel

The Horne TSV1-3 thermostatic shower valve is WRAS & TMV3 Scheme Approved.



Certificate No. FM

Dimensions in mm

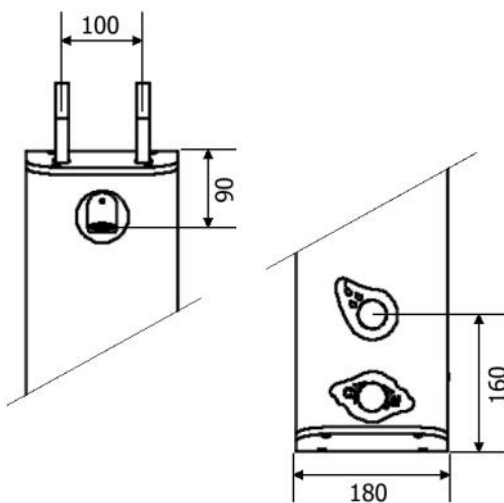
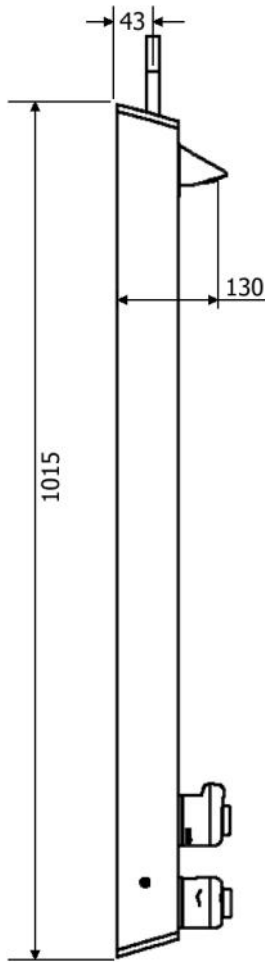

The T105A2L shower panel is pre-plumbed with an integral, dual control, Type 3 approved thermostatic mixing valve, which features:



- Integral fine mesh strainers provide essential protection to internal mechanism of the valve and ancillary fittings
- Angle pattern inlets enable easy access to the strainers
- Integral check valves prevent cross migration of water supplies
- Flushing facility to allow water supplies to be flushed clean during commissioning

### Operating Conditions:

- Range of temperature adjustment up to pre-set maximum
- Range of hot water supply temperature: 52 — 85°C
- Maximum static pressure: 10 bar
- Minimum differential between hot water temp. and mixed water temp.: 5°C
- Range of maintained water supply pressures: 0.2 — 5 bar

Hot and cold water pressures do not need to be equal. The lower of the two pressures, however, should not be less than 0.2 bar maintained at the shower head.