

T105A DUAL CONTROL SHOWER PANEL

HORNE TSV1 SHOWER PANEL WITH DUAL CONTROL THERMOSTATIC MIXING VALVE AND VANDAL RESISTANT SHOWER HEAD

Includes integral TMV3 Scheme Approved thermostatic shower valve pre-plumbed within a white (RAL 9010) powder coated aluminium panel with hand controls and vandal resistant shower head in chromium plated finish.



FEATURES & BENEFITS

- Robust, powder coated (RAL 9010) panel and fittings ensure long lifespan
- Pressure & tested pre-plumbed assembly
- Integral TMV3 Scheme Approved shower valve - dual control
- Fixed vandal resistant shower head
 - * Large size spray plate
 - * Two directional spray settings
 - * Easy to clean and maintain
- Integral 8 L/min flow regulator for water and energy conservation
- Low level integral isolating service valves for ease of maintenance
- Highly suitable for retrofit applications
- Fast and easy installation
- Optional accessory:
 - Pipe cover in same profile as panel

The Horne TSV1-3 thermostatic shower valve is WRAS & TMV3 Scheme Approved.



Certificate No. FM 1224

Dimensions in mm

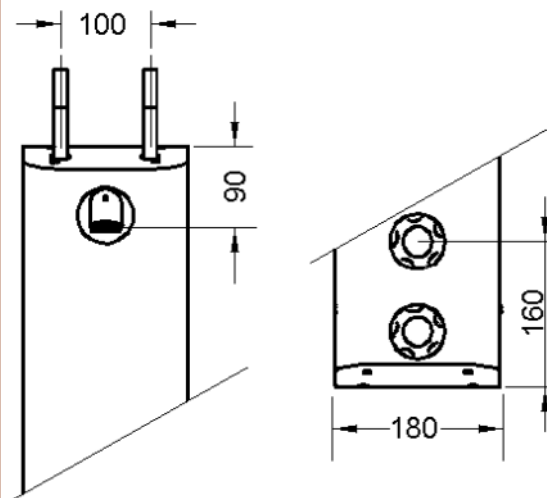
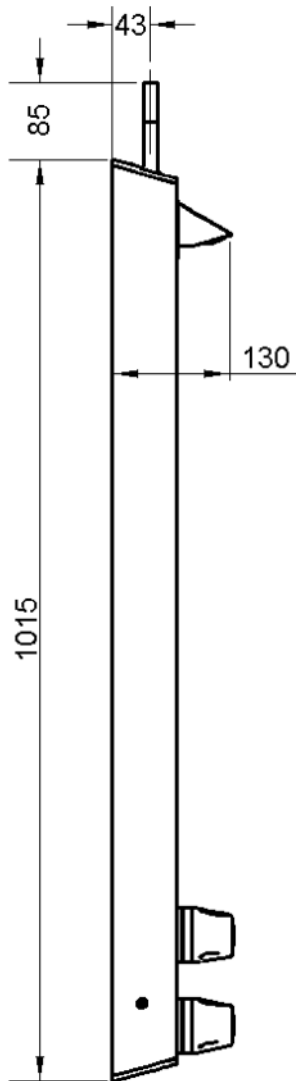

The T105A shower panel is pre-plumbed with an integral dual control Type 3 approved thermostatic mixing valve, which features:



- Integral fine mesh strainers provide essential protection to internal mechanism of the valve and ancillary fittings
- Angle pattern inlets enable easy access to the strainers
- Integral check valves prevent cross migration of water supplies
- Flushing facility to allow water supplies to be flushed clean during commissioning

Operating Conditions:

- Range of temperature adjustment up to pre-set maximum
- Range of hot water supply temperature: 52 — 85°C
- Maximum static pressure: 10 bar
- Minimum differential between hot water temp. and mixed water temp.: 5°C
- Range of maintained water supply pressures: 0.2 — 5 bar

Hot and cold water pressures do not need to be equal. The lower of the two pressures, however, should not be less than 0.2 bar maintained at the shower head.

HORNE ENGINEERING LTD, PO BOX 7, Rankine Street, Johnstone, PA5 8BD.

Tel: +44 (0)1505 321455 Fax: +44 (0)1505 336287 Email: sales@horne.co.uk web: www.horne.co.uk