

### T307B SHOWER PANEL

HORNE SHOWER PANEL WITH PUSH BUTTON TIMED FLOW CONTROL, FLEXIBLE HOSE, SLIDE BAR AND THREE FUNCTION SHOWER HEAD

Includes TMV3 Scheme Approved HORNE 15 thermostatic mixing valve pre-plumbed within a white powder coated aluminium panel with push button timed flow control and shower kit comprising chromium plated three function easy clean shower hand set with flexible hose and slide bar. Connections by flexible Soft-PEX braided hose for concealed water supplies.



### FEATURES & BENEFITS

- Durable powder coated panel and robust fitting ensures long lifespan
- Pressure and performance tested pre-plumbed assembly
- Integral TMV3 Scheme approved HORNE 15 thermostatic mixing valve
- Three function handset with flexible anti-kink hose and slide bar
- Timed flow control for water and energy conservation (approx. duration 45 seconds)
- Integral 8 L/min flow regulator for water and energy conservation
- Low level isolating service valves for ease of maintenance
- Highly suitable for retrofit applications
- Fast and easy installation
- Optional Accessory  
- 2m hose (Part No. SA-108B)



The HORNE 15 thermostatic mixing valve is WRAS & TMV3 Scheme Approved.

Certificate No. FM 1224

Dimensions in mm

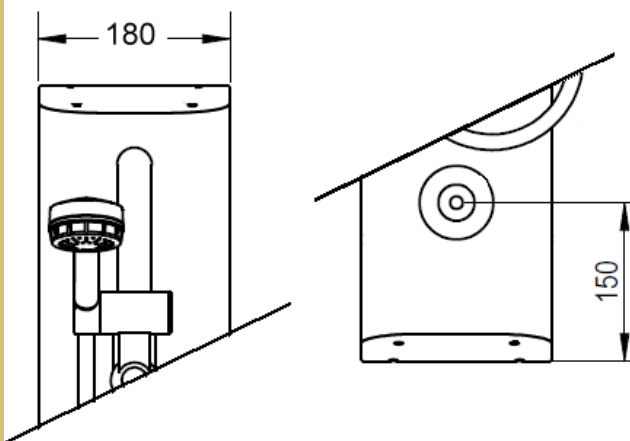
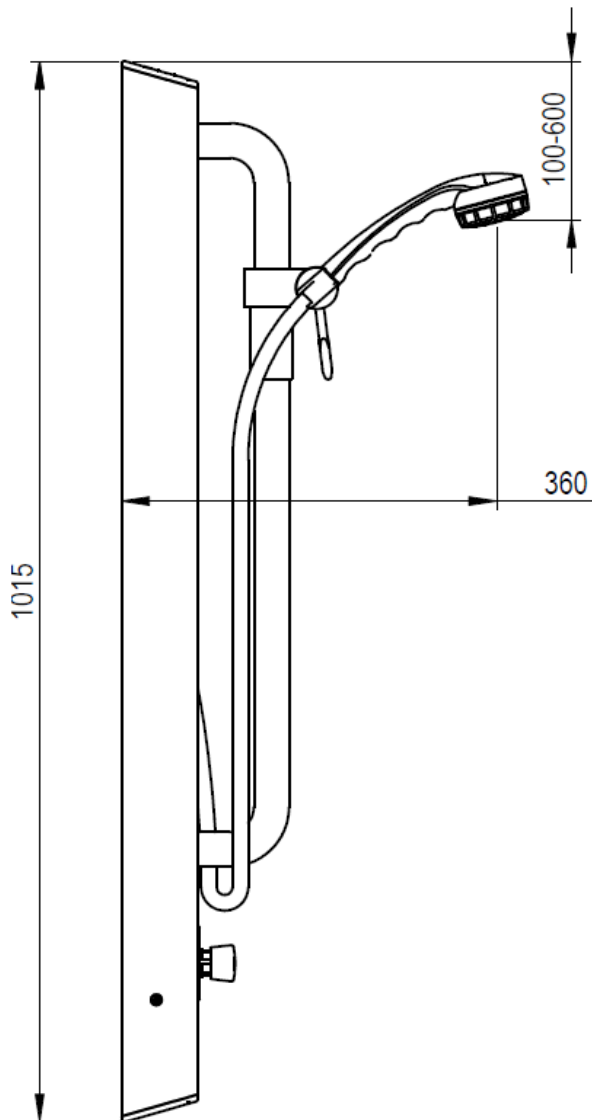

The T307B shower panel is pre-plumbed with an integral Type 3 approved thermostatic mixing valve, which features:



- Low level isolating servicing valves
- Integral fine mesh strainers provide essential protection to the internal mechanism of the valve & ancillary fittings
- Angle pattern inlets enable easy access to the strainers
- Flushing facility allows water supplies to be flushed clean during commissioning
- Integral check valves prevent cross migration of water supplies

### Operating Conditions:

- Mixed water temp. preset to 41°C
- Range of hot water supply temperature: 52 — 85°C
- Maximum static pressure: 10 bar
- Minimum differential between hot water temp. and mixed water temp.: 5°C
- Range of maintained water supply pressures: 0.5 — 5 bar

Hot and cold water pressures do not need to be equal. The lower of the two pressures, however, should not be less than 0.5 bar maintained at the shower head.

HORNE ENGINEERING LTD, PO BOX 7, Rankine Street, Johnstone, PA5 8BD.

Tel: +44 (0)1505 321455 Fax: +44 (0)1505 336287 Email: sales@horne.co.uk web: www.horne.co.uk