

HORNE BIMODAL, LIGATURE RESISTANT TSV1 SHOWER PANEL WITH DUAL CONTROL THERMOSTATIC SHOWER VALVE, VANDAL RESISTANT SHOWER HEAD, DETACHABLE HOSE AND HANDSET, ILTDU AND PIPE COVER. Includes integral TMV3 Scheme approved thermostatic shower valve pre-plumbed within a white powder coated aluminium panel with auto divert, ligature resistant hand controls, ligature resistant shower head, detachable hose with single function handset, integral In-line Thermal Disinfection Unit and 940mm Pipe Cover.



FEATURES & BENEFITS

- Robust, anodised and powder coated (RAL 9010) panel and fittings ensure long lifespan
- Integral TMV3 Scheme approved TSV1 shower valve with ligature resistant dual controls
- In-Line Thermal Disinfection Unit with easy operation for periodic disinfection of pipework, valve and downstream fittings using local hot water supply
- 940mm Pipe Cover in same profile as panel with key access point for ILTDU operation
- Fixed ligature resistant shower head (*unsupervised mode*). Easy to clean and maintain with large area spray plate and two directional spray settings
- Detachable 2m hose (PVC liner), easy-clean and anti-kink, with single function handset (*assisted mode via integral diverter valve*)
- Integral flow regulator for water and energy conservation, optimised flow 8-11 L/min
- Low level integral servicing valves for ease of maintenance and performance testing
- Highly suitable for retrofit applications
- Fast and easy installation
- Full assembly factory pressure tested to 16 bar

The Horne TSV1-3 thermostatic shower valve is WRAS & TMV3 Scheme Approved.



Certificate No. FM 1224

The **T605T9LR** shower panel is pre-plumbed with an integral dual control Type 3 approved thermostatic mixing valve, which features:

- Low level isolating servicing valves
- Integral fine mesh strainers provide essential protection to internal mechanism of the valve and ancillary fittings
- Angle pattern inlets enable easy access to the strainers
- Integral check valves prevent cross migration of water supplies
- Flushing facility to allow water supplies to be flushed clean during commissioning

Operating Conditions:

- Range of temperature adjustment up to pre-set maximum, usually 41°C at the shower head
- Range of hot water supply temperature: 52 — 85°C
- Maximum static pressure: 10 bar
- Minimum differential between hot water temp. and mixed water temp.: 5°C
- Range of maintained water supply pressures: 2-5 bar

Hot and cold water pressures do not need to be equal. The lower of the two pressures, however, should not be less than 2 bar maintained at the shower head.

Dimensions in mm

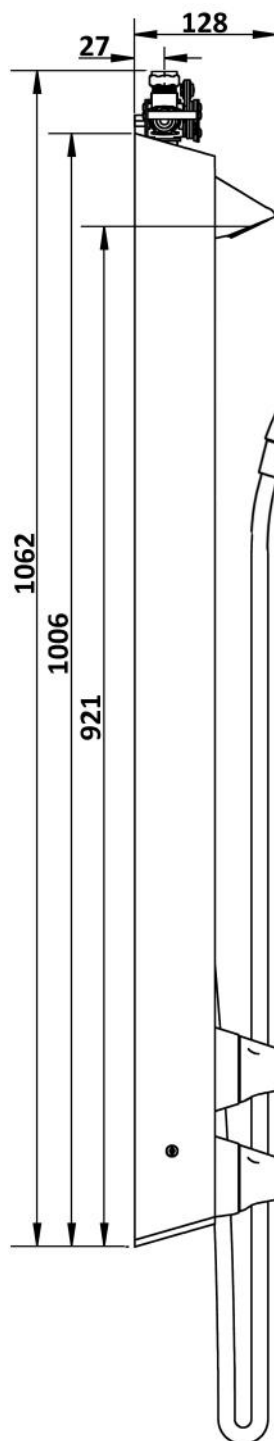

Original Drawing Ref: 11355

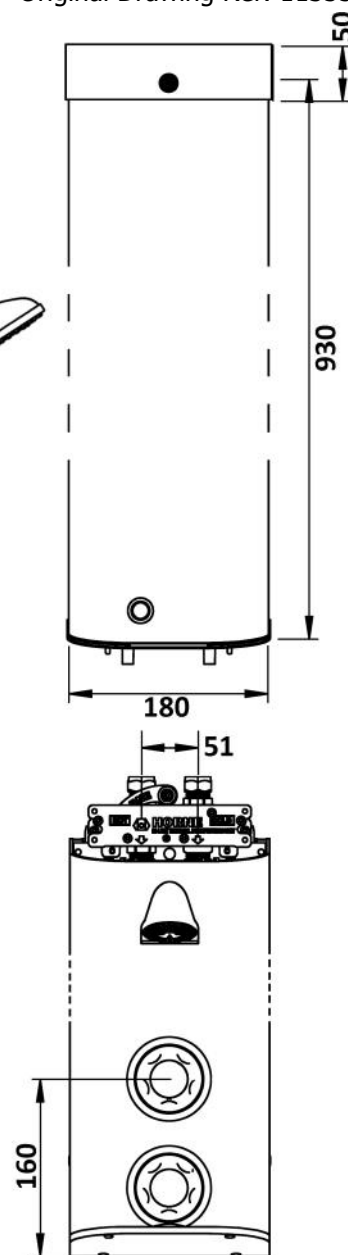

TOTAL HEIGHT OF PANEL + PIPECOVER
= 1006 + 2 + 930 + 50 - (OVERLAP)

- OVERLAP IS VARIABLE, 20-40MM
- 930 LENGTH CAN BE CUT TO SUIT

Thermal Disinfection using the ILTDU

For an explanation of its operating principals and further information on the recommended disinfection procedure, please refer to our ILTDU brochure and instructions.

